

DRONE

60CM INDUSTRIAL DRUM FAN

Spec Sheet

Main Features

- Long life motor with 100% copper wire
- Heavy duty gauge steel casing, guard and frame
- Quality construction with balanced blades
- 360° tiltable head
- 3 speeds rotary switch settings
- Portable movement assisted by wheels
- Ultra-high 11,780 m³/h airflow
- 1.6m flexible power cord with plug supplied
- 12 months warranty

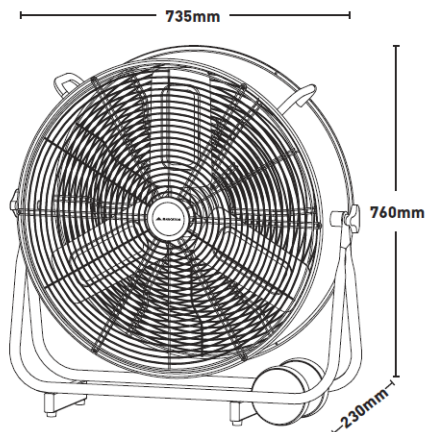

Product Technical Specifications

Colour/Finish option	Black
Blade	3 x aluminium blades
Rated input voltage	220-240V~
Rated input frequency	50Hz
Motor power	265W
Airflow	Up to 11,780 m ³ /hr
Tilt angle	360°
Gross weight	14.3 kg
Net weight	12.3 kg
Packaging	Printed box
Packaging size (mm)	L730 mm x W240 mm x H780 mm

Bar Codes

SKU Model	Finish	Bar Code
FF71424BK	Black	9312699203879